

# electriciQ

## USER MANUAL

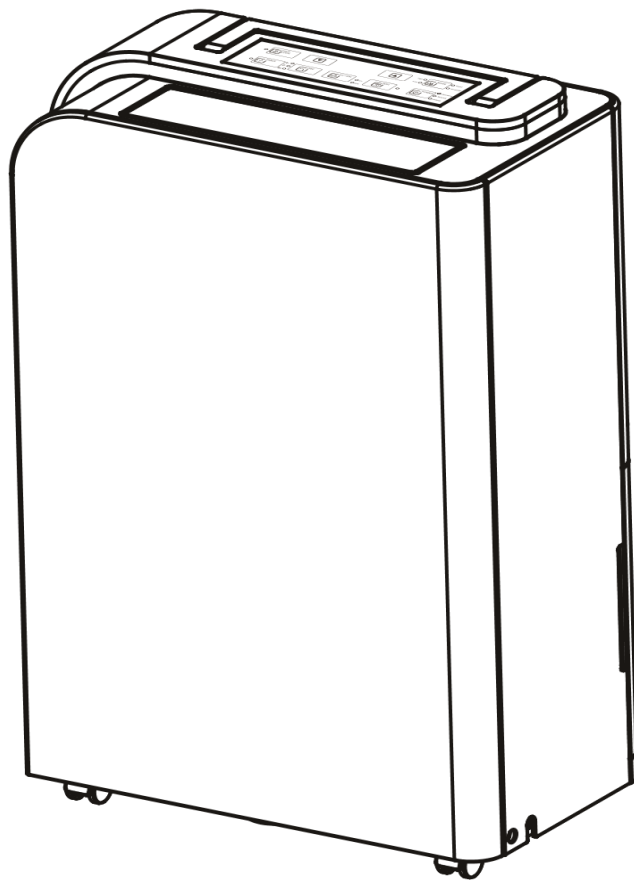

**PREMIUM DEHUMIDIFIER WITH DIGITAL HUMIDISTAT  
WITH AIR PURIFIER, UV AND PLASMA IONISER AND  
SMART WIFI APP CONTROL**

**CD25PRO-LE-V2 - 25L Litres per day**

Thank you for choosing electriciQ

Please read this user manual before using this innovative

Dehumidifier and keep it safe for future reference

Visit our page [www.electriQ.co.uk](http://www.electriQ.co.uk) for our entire range of Intelligent Electricals

# CONTENTS

SAFETY INSTRUCTIONS	3
ENERGY SAVING	5
INSTALLATION	6
FEATURES	6
PARTS	7
CONTROL PANEL	8
QUICK REFERENCE GUIDE	10
OTHER FEATURES AND INDICATORS	12
POSITIONING THE DEHUMIDIFIER	13
WATER DRAINAGE	14
SETTING UP THE WIFI	16
CONTROLLING YOUR DEVICE THROUGH THE APP	21
CARE AND MAINTENANCE	26
FREQUENTLY ASKED QUESTIONS	27
TROUBLESHOOTING	28
TECHNICAL SPECIFICATION	29
SUPPORT	29

# SAFETY INSTRUCTIONS

## IMPORTANT

- Carefully read the instructions before operating the unit.
- This appliance is only intended for use in an indoor domestic environment. Any other use is not recommended by the manufacturer and may cause fire, electrical shock or other injuries to person or damage to property.
- Rating: This unit must only be connected to an AC 220-240V / 50 Hz earthed outlet. Installation must be in accordance with the regulations of the country where the unit is used.
- If you are in any doubt about the suitability of your electrical supply, have it checked and, if necessary, modified by a qualified electrician.
- This dehumidifier has been tested and is safe to use. However, as with any electrical appliance – care must be taken during use.
- Disconnect the power from the appliance before dismantling, assembling or cleaning.
- Avoid touching any moving parts of the appliance.
- Never insert fingers, pencils or any other objects through the guard.
- This appliance is not intended for use by persons (including children) with reduced physical, sensory or mental capabilities. It is also not intended for use by those with a lack of experience and knowledge unless they have been given supervision or instruction concerning the use of the appliance by a person responsible for their safety.
- Do not leave children unsupervised with this appliance.
- Do not clean the unit by spraying it or immersing it in water.
- Never connect the unit to an electrical outlet using an extension cord. If a power outlet is not available, one should be installed by a qualified electrician.
- Never operate this appliance if the cord, power adapter or plug is damaged. Ensure the power cord is not stretched or exposed to sharp object/edges.

- A damaged power supply cord should be replaced by the manufacturer or a qualified electrician in order to avoid a hazard.
- Any service other than regular cleaning or filter replacement should be performed by an authorized service representative. Failure to comply could result in a voided warranty.
- Do not use the appliance for any purpose other than its intended use.
- Do not tilt the unit while in use. The unit is designed to work only in a vertical position. This dehumidifier must always be stored upright, otherwise irreparable damage may be caused.
- This unit will still operate for approximately 3-4 minute after pressing the power button to turn off. This is normal and ensures the desiccant wheel is drained of water. Avoid restarting the dehumidifier until 5 minutes have passed after being turned off.
- Never use the mains plug as a switch to start or turn off the dehumidifier. Use the provided power button located on the control panel.
- Always place the unit on a dry and stable surface.
- The appliance should not be installed in a laundry or wet room where the humidity is higher than 85% RH. This unit should be operated at an ambient temperature between 1°C and 32°C.
- Do not dry laundry directly above the unit. To prevent water from entering the dehumidifier, laundry should be placed at least 40 cm away from your dehumidifier.
- Do not place the unit next to heat sources (e.g. electrical fires, fireplaces, etc.)
- Desiccant dehumidifiers tend to absorb odours from the surrounding environment like cigarettes, cooking, cosmetics, new furniture etc. This smell is described as a burning or sour smell. This is released during operation as the zeolite disc is heated. This is not a sign of a fault and the smell will fade after usage.
- Do not store or use gasoline, petrol, paint, solvents or other flammable vapours and liquids in the vicinity of this dehumidifier or any other appliance. Do not use dehumidifiers where flammable gases or VOC can be released or accumulate.

## ENERGY SAVING AND UNIT SAFETY PROTECTION TIPS

- Do not cover or restrict the airflow from the outlet or inlet grills.
- For maximum performance, the unit should be operated at least 20 cm away from walls and 50 cm from other objects within the room.
- Keep the filters and grills of the appliance clean. Under normal conditions, filters and grills should only need cleaning once every three weeks (approximately). Do not use the unit without the mesh air filter as this will allow dirt to gather inside the dehumidifier, which could invalidate the warranty.
- A dirty filter will restrict the airflow into the machine, which will increase the resistance on the fan and could result in damage and might invalidate the warranty.
- Since the filters remove airborne particles, more frequent cleaning may be necessary depending on the air quality. Vacuum and wash the mesh filters with hot soapy water and dry them before placing them back in the unit.

**NOTE:** All information provided is for reference only. Products specifications may change due to continuous product development.

### QUICK VISUAL SAFETY GUIDE ON WHERE OR WHEN NOT TO USE YOUR DEHUMIDIFIER



Exposed to the weather outdoors



Near water



If the power cable wires are frayed or cut



Where small children may be left unattended



If an extension lead may become overloaded



Where it may be damaged by chemicals



Where the power cable may be damaged



Where there is a risk of interference by foreign objects



On a slope or uneven surface



This product is not for DIY repair



Where there is a risk of fire, or close to a naked flame



Where there is a risk of water falling on the unit

## **INSTALLATION**

Remove any water from within the water tank before starting the unit. In order to save energy do not open windows or doors while the unit is running. Place the unit on a hard / flat surface. On first use run the unit continuously for 24 hrs.

## **TO REDUCE NOISE LEVELS**

Place a piece of carpet or a rubber mat under the unit to reduce any vibrations while the unit is running.

The dehumidifier uses compressor technology to extract water from the environment. Compressor dehumidifiers are ideal for normal domestic or office environments which are heated during the winter months and maintain a temperature above 12-15°C.

The dehumidifier is easy to move around on castors and is designed to extract unwanted humidity while saving money due to its power saving logic. It features an intelligent humidistat where the desired relative humidity can be adjusted in increments of 5% between 40% and 80% ensuring your room is not dried too much and power is not wasted.

## **FEATURES**

Your dehumidifier is part of the electriQ low energy premium dehumidifier range featuring low power consumption, power saving logic and advanced air purification.

1. Easy to use controls
2. Low energy – Only uses a fraction of the electricity of similar dehumidifiers
3. Great for up to 5 bed houses
4. Cost effective way to combat mould, condensation and damp
5. Dries laundry more efficiently than a tumble dryer
6. Designed to complement any modern space
7. Low and High fan speed selection for best balance between running quiet and maximum water extraction
8. Anti-dust self-closing oscillating louvres for improved air flow
9. Castors for improved mobility
10. Intelligent CPU controlled digital humidistat with 35-80% RH and room humidity display
11. 24 hours start / stop timer
12. Tank operation or permanent drainage option with splash proof tank
13. Tank full alarm & auto-stop function
14. Air purifier with plasma ioniser and UV Sterilisation.
15. Remote control with integrated humidistat and follow me function which adjusts the operation of the unit according to where the remote is situated.
16. App control, allowing the unit to be remote scheduled and settings to be changed from Android and IOS – great for caravans, holiday homes, museums, children rooms, offices etc.

## PARTS

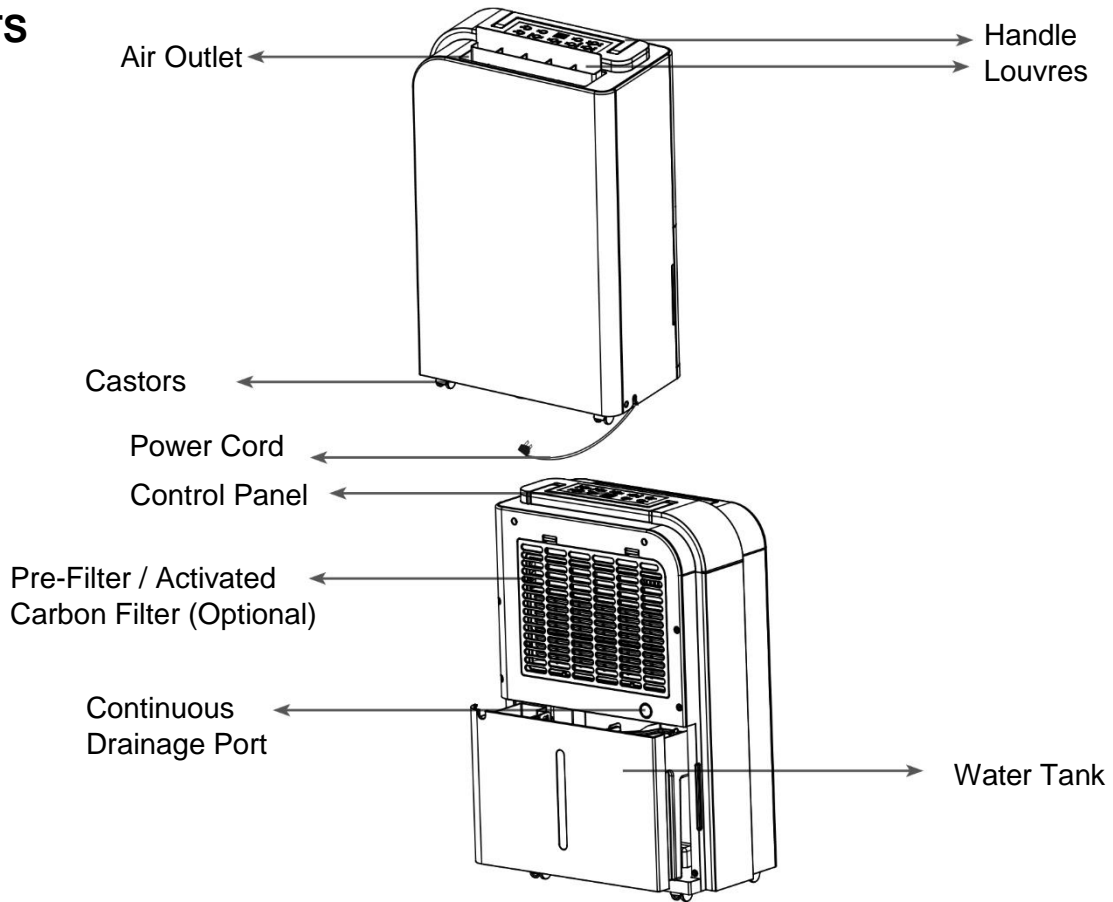

## ACCESSORIES

Activated carbon filter (Optional)

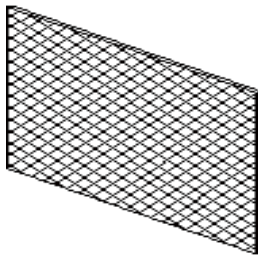

HEPA FILTER

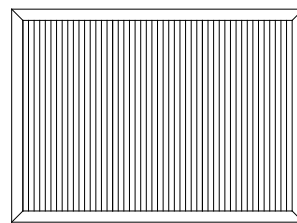



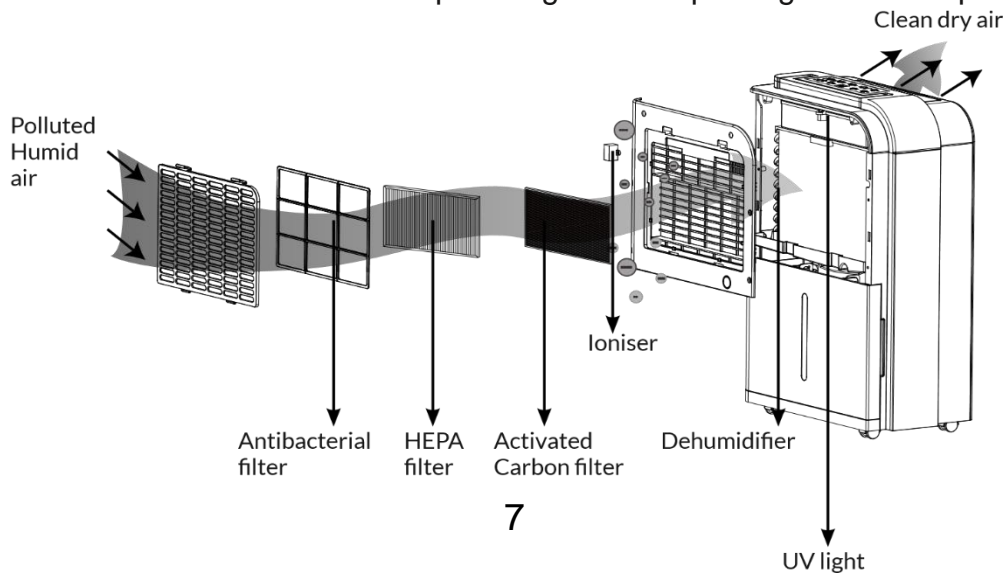

6 stage dual action dehumidifier and purifier great in improving indoor air quality

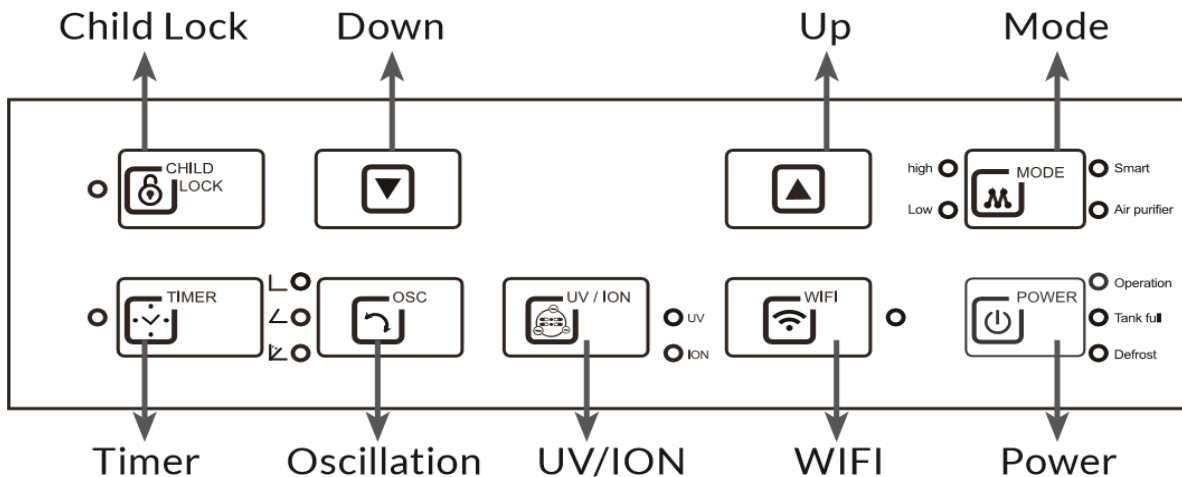





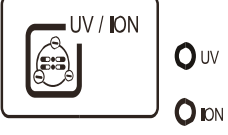

# CONTROL PANEL



	<p><b>POWER BUTTON</b> Turns the appliance on/off</p>
	<p><b>MODE BUTTON</b> Select the function of the unit between SMART / HIGH / LOW / and Air Purifier. The LED's next to the button will show which mode is selected. <b>SMART MODE:</b> The unit will default to SMART mode the first time it is switched on and remains in this mode until another program is chosen. In smart mode, it will aim for a relative humidity of 50-55%, and the fan speed will be adjusted automatically. <b>HIGH:</b> The unit will dehumidify and aim for the humidity set using the up and down buttons. <b>LOW:</b> The unit will dehumidify and aim for the humidity set using the up and down buttons. <b>AIR Purifier:</b> Only the fan will run and water is not extracted. The filters will purify the air. The UV and Plasma ioniser can also be used to further improve the air quality.</p>
	<p><b>CHILD LOCK BUTTON</b> Hold this button for 3 seconds to activate or deactivate the child lock. While activated, the control panel on the unit will not respond to any presses. Please note the child lock is only available when the remote screen is on.</p>
	<p><b>OSC. (Oscillation function) BUTTON</b> There are three different options for the outer louvre on the unit. It can be set at 45 or 90 degrees, or alternatively to swing. Use the dehumidifier at a 45-degree angle or with the swing function for Laundry mode</p>
	<p><b>UV &amp; ION BUTTON</b> This operates both the Ioniser and UV modes. You can use the loniser and UV sterilisation individually or combine them for increased effectiveness. The indicators will show which function is currently running. Repeatedly press the UV/ION button to change between the options.</p>



	<p><b>WIFI BUTTON</b></p> <p>Press and hold the WIFI button for 3 seconds to activate the WIFI connection mode. The WIFI indicator light will be illuminated. See the WIFI guide within this manual for further information on how to set it up.</p>
	<p><b>HUMIDITY SETTING</b></p> <p>Press the UP and DOWN buttons to select the desired relative humidity level. The default relative humidity is 55%. When a relative humidity of 35% is selected, the compressor will not stop until the water tank is full.</p> <p><b>NOTE:</b> The desired humidity cannot be changed in SMART mode.</p>
	<p><b>TIMER</b></p> <p>Press the TIMER button to program the timer. When the timer is activated, the "TIMER" light will illuminate. Before programming the timer, ensure the timer function has not been activated (the light must be off). The following timer programs are available.</p> <p><b>DELAYED POWER-ON FUNCTION:</b> With the appliance in standby, press the TIMER button, then use the UP and DOWN buttons to set in how many hours' time you require the unit to start (0~24 hours).</p> <p><b>DELAYED POWER-OFF FUNCTION:</b> While the appliance is running with the desired settings, press the TIMER button, then use the UP and DOWN buttons to set in how many hours' time you require the unit to stop (0~24 hours).</p>
	<p><b>INTELLIGENT DEFROST</b></p> <p>The appliance will defrost automatically when the coil sensor detects that the internal temperature is too low. During defrosting the indicator will light up. Once the defrost cycle has finished, the appliance will return to the mode that was previously operating.</p>
	<p><b>TANK-FULL</b></p> <p>When the water tank is full, the TANK FULL indicator light will flash, and the unit will stop operating. Once emptied and replaced, the appliance will resume operation.</p>
	<p><b>OPERATION</b></p> <p>The Operation light will illuminate when the compressor within the unit is running to extract moisture from the air. Please note this may not light up immediately when the unit is started, and will go out when the desired humidity is reached.</p>

## HUMIDITY LEVEL & TIMER 2 DIGIT DISPLAY

The led indicator performs the following functions:

- 1 When the unit is plugged in, it will indicate the humidity level of the room.
- 2 When the UP and DOWN buttons are pressed, it will indicate the desired humidity currently set.
- 3 When the timer is programmed will show the duration.



**NOTES:** When humidity level is outside the normal operational parameters will show LO/HI. If ambient humidity is lower than 20%, it will show "LO" If ambient humidity is higher than 90%, it will show "HI". When HI/LO is displayed, the unit will not operate until the humidity has returned to the normal range.

## QUICK REFERENCE GUIDE

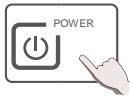

**POWER BUTTON:** Press to turn the unit ON/OFF.



**OSCILLATION BUTTON:** Press once to make the louvre swing and press again to lock at 45 degrees, press again to lock at 90 degrees. Do not operate the unit if the self-opening louvers do not open on power on.



**TIMER:** Press the timer button, then use the UP and DOWN buttons to adjust the duration of the timer (1-24 hours, START/STOP timer)

### IF SET WHILE THE UNIT IS RUNNING

The number will represent the number of hours the unit will operate before turning off. This will not be affected if the unit enters defrost mode or the tank is emptied and reinserted.

### IF SET WHILE THE UNIT IS IN STANDBY

The set number represents the period in hours after which the unit will start. To cancel start / stop mode press the timer key again.

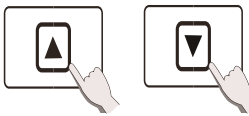

**UP AND DOWN BUTTONS:** During the High or Low modes when the unit is displaying the current relative humidity, these buttons can be used to adjust the desired humidity level. The desired relative humidity can be set between 35 and 80% in 5% increments.

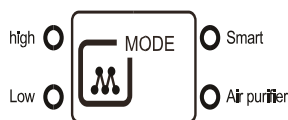

**SMART MODE:** This is designed for maximum convenience and maintains the ideal domestic environment humidity level of 50-55% while saving electricity. This is the default mode and is recommended for most users.

During operation the compressor will operate until the desired humidity is reached and then will stop. The economical low air purifier mode will continue to operate. The fan moves the air around the room ensuring all the air in the room is processed and the humidity is correctly measured.

To achieve drier air, or while drying laundry, put the unit in High mode and use the down button to select a lower desired humidity (e.g. 35-45%).

## **LAUNDRY MODE**

When drying clothes, it is advised for the dehumidifier to operate continuously with maximum water extraction until the water tank is full. Set the unit to the High mode, and set the desired humidity level between 35%-50%. 35% is very dry and is hardly achievable in a UK domestic environment. As such the unit will work until the water tank is full when set to 35%. Set the louvres to swing mode or to 45 degrees directing the airflow onto the clothes. Do not place clothes directly over any of the vents on the dehumidifier. Make sure that there is nothing blocking the hot air exhaust air flow and for best results place the laundry within 1.5 meters of the dehumidifier.

## **NOTES**

- If a permanent drainage pipe is fitted the unit will not stop operating. Setting the desired humidity to around 35% is good for laundry mode, a quick drying boost, or in emergencies. It is not recommended for long normal operation in a domestic or office environment.
- To allow more moisture in the air, press the up button and set to a higher desired humidity (e.g. 60-70%).
- We recommend setting the Humidity to 50-55%. This is great for domestic operation and dry storage
- Setting the humidity to 60% is great for personal comfort and applications where 50% RH is considered too dry
- Setting the humidity to 70% is ideal for unoccupied properties or where an economical run is needed without the need to reduce the humidity further.

## **OTHER FEATURES AND INDICATORS**

### **TANK FULL LIGHT**

When the water tank is full, removed or incorrectly inserted the unit will stop dehumidifying, the red tank full light will illuminate and the unit will beep. Empty the tank and reinsert it correctly to resume operation.

### **AUTO DEFROST**

When frost builds up on the evaporator coils, the compressor will cycle off and the unit will go in to defrost mode. Following completion of the defrost mode, the unit will return to the previously operating settings.

- When the unit is running in a room with a temperature between 5°C and 12°C, it will enter defrost mode roughly every 30 minutes.
- When the unit is running in a room with a temperature between 12°C and 20°C, it will enter the defrost mode roughly every 45 minutes.

### **HUMIDISTAT CONTROL AND FAN/COMPRESSOR OPERATION**

- When the humidity of the room is 2% lower than the desired humidity the compressor will turn off automatically but the fan will continue to operate to ensure that the air within the room is not stale. The unit will use only a minimal amount of energy in fan mode.
- When the humidity of the room is equal to or higher than the desired humidity the compressor will restart after a 3 minutes delay to protect the compressor.

### **AUTO-RESTART (on some models)**

If the unit stops unexpectedly due to the power cut, it will restart with the previous function selected automatically when the power resumes, and the 3-minute compressor protection has elapsed.

### **POWER**

After the unit has stopped, to protect the compressor it is not recommended to resume operation for at least 10 minutes. Operation can resume after this period lapses. When the unit is restarted there is a 3 minutes delay before compressor will start.

### **LIGHTWEIGHT PORTABLE DESIGN ON CASTORS**

The dehumidifier is built to be compact and lightweight. The castors on the bottom of the unit make it easy to move from room to room.

Your dehumidifier contains an advanced micro-CPU controlled device which is capable of self-diagnostics. The LCD display may also show the error and protections codes.

## POSITIONING THE DEHUMIDIFIER

A badly positioned dehumidifier will have little effect. When positioning the dehumidifier please ensure circulation of air is not restricted around the unit.

Allow at least 20 cm of space around the unit. This dehumidifier is designed only for indoor residential or small office applications and any commercial or industrial use will invalidate the warranty.

Use in an enclosed area for maximum efficiency. Close all doors and windows to create an effective operating environment. Do not use outdoors.

Your electriQ dehumidifier will begin to protect your space from the harmful effects of excessive moisture as soon as it is turned on.

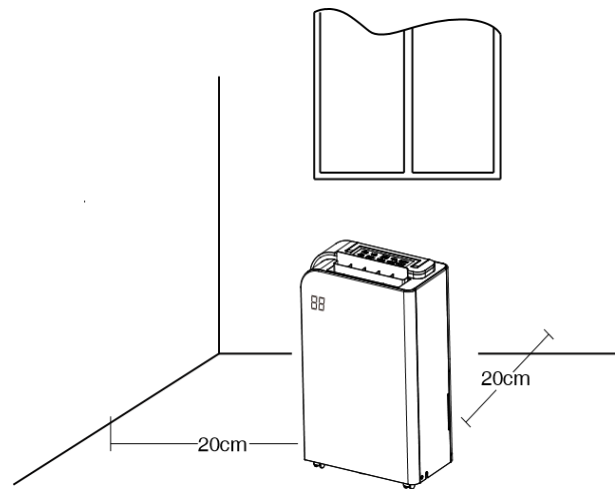

The dehumidifier should be positioned in a central and clear location so that it can draw this moist air towards it from all over the home. A warm hallway or landing is an excellent position for your dehumidifier. If possible, leave interior doors ajar to allow air circulation.

Alternatively, if you have a serious problem in one area you can begin by positioning the dehumidifier there and moving it to a more central location at a later date. For the most effective use, run your dehumidifier with external doors and windows kept closed. Please note the unit should not be placed directly against a radiator or other heat source.

When positioning your electriQ dehumidifier, ensure that it is placed clear of any obstacle that may limit the air movement. Place the dehumidifier on a flat dry surface.

**NOTE:** Do not force castors to move over carpet or uneven surfaces, or move the unit with water in the tank as it may tip over and spill water.

## WATER DRAINAGE

When the water tank is full, the unit will stop automatically. When this happens the **TANK FULL** red light will show on the control panel, and the unit will bleep.

There are two ways to dispense collected water. It can be either collected within the internal tank or expelled through a drainage hose (not supplied) using continuous drainage.

### USE THE TANK

When the tank is full, the unit will automatically stop running, and the Tank Full indicator light will flash. Grip the tank by its handle securely, and carefully pull out. Empty the water tank and reinsert it into the dehumidifier. The tank must be in place and securely seated for the dehumidifier to operate again. The dehumidifier will re-start when the tank is restored to its correct position.

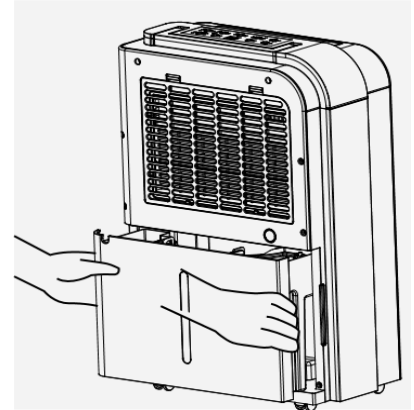

### NOTES:

- Do not remove the water tank immediately after the unit stops. Please wait a while to avoid the water dripping into the unit and causing damage.
- Only empty the water tank when it is full or before moving or storing the unit.
- Do not rest the tank on the floor because the bottom of the tank could be uneven and tank may fall and cause the water to spill.
- When you remove the tank, do not touch sensors or any parts which are situated behind tank. Doing so may damage the product. Be sure to push the tank gently all the way into the unit. Banging the bucket against anything or failing to push it securely into place may cause the unit not to operate.
- Do not remove or damage the float switch in the water-tank, otherwise the machine will stop working.
- Please make sure the water tank cover is put back into place correctly before the water tank is reinserted.
- If the water-tank is inserted incorrectly, the tank full indicator will flash. Remove the water tank and reinsert to turn the indicator off and resume normal use.
- At all times, avoid water entering the unit. It may cause an electrical hazard and damage the unit.

## CONTINUOUS DRAINAGE

This dehumidifier has a continuous drain hole that can be connected to a plastic pipe with a 15 mm inner diameter (Not Supplied). Water can be automatically plumbed in or drained into a sink, a larger receptacle or through the wall into an outside drain. Please follow the steps below to set your unit up for continuous drainage.

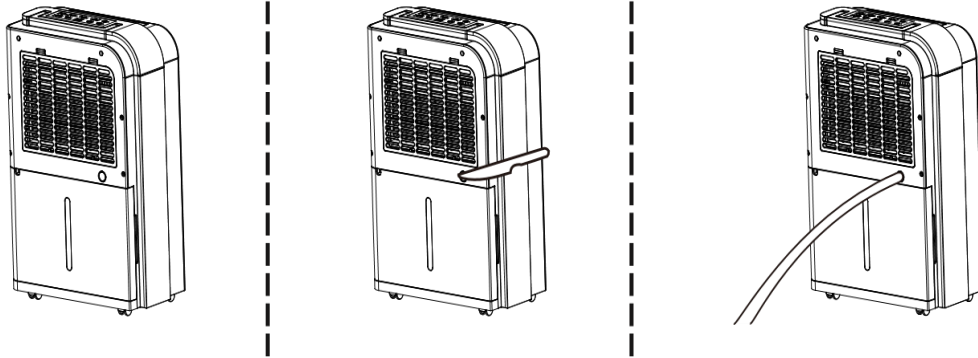

1. Cut off the cover for the continuous drain on the back of the unit.
2. Pull out the water tank and connect a water tube of inner diameter 15mm to the drain connector, and ensure the connection is tight \* Please note, the water tube is not supplied with the unit.
3. Return the water tank back into position within the unit.

This unit uses gravity fall to dispose water hence the drain should be lower than the dehumidifier water outlet. Be sure to run the water pipe downward and let the water flow out smoothly. Do not kink or bend the pipe.

### NOTES:

- When the continuous drain feature is not being used, reverse the pipe installation, to start the water collecting in the water tank.
- The permanent drain can be used in conjunction with a water pump (e.g. when draining from a cellar) to lift the water upwards.

## SETTING UP THE WIFI APP

This is designed as a general guide to the setup. There may be differences in the interface and features available due to product development and features of the model.

### BEFORE YOU START

- Ensure your router provides a standard 2.4ghz connection.
- If your router is dual-band ensure that both networks have different network names (SSID). The provider of your router / Internet service provider will be able to provide advice specific to your router.
- Place the dehumidifier as close as possible to the router during setup.
- Once the app has been installed on your phone, turn off the data connection, and ensure your phone is connected to your router via WiFi.

### DOWNLOAD THE APP TO YOUR PHONE

Download the "TUYA SMART" app, from your chosen app store, using the QR codes below, or by searching for the app in your chosen store.



Android



IOS

### CONNECTION METHODS AVAILABLE FOR SETUP

The smart device has two different setup modes, CF (Quick Connection) and AP (Access Point). The quick connection is a quick and simple way to set the unit up. AP connection uses a direct local WiFi connection between your phone and the dehumidifier to upload the network details.

Before starting the setup, please ensure that your dehumidifier is in the correct standby mode for the connection type you are attempting, the display your dehumidifier will indicate this.

### CHANGING BETWEEN CONNECTION MODES / WIFI RESET

To change the unit between the two connection types, hold the WIFI button for 3 seconds. The connection mode is signified by the frequency of the flashing WIFI light. This will also remove any previous WIFI configuration.

Connection Type	Frequency of Flashes
CF (Quick Connection)	Flashes twice per second
AP (Access Point)	Flashes once per two seconds



# REGISTER THE APP

1. Press on the register button at the bottom of the screen.

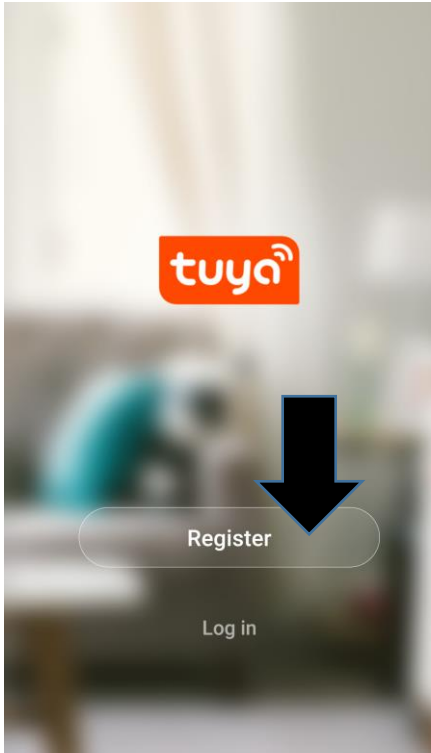

2. Read the Privacy policy and press the Agree Button.

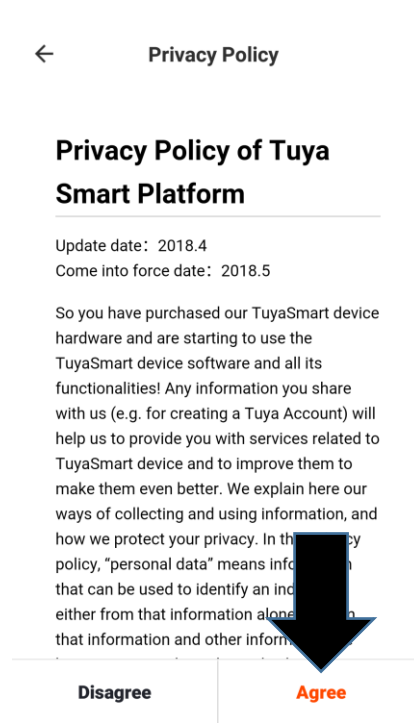

3. Enter your email address or phone number and press continue to register.

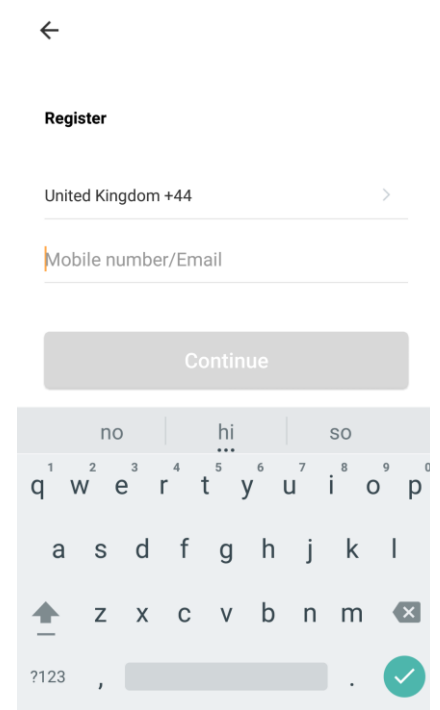

4. A verification code will be sent by the method selected in step 3. Enter the code into the app.

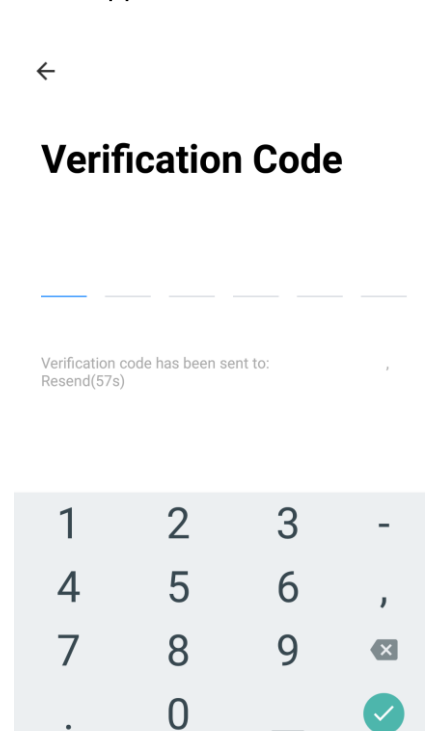

5. Type in the password you would like to create. This needs to be 6-20 characters, with letters and numbers.

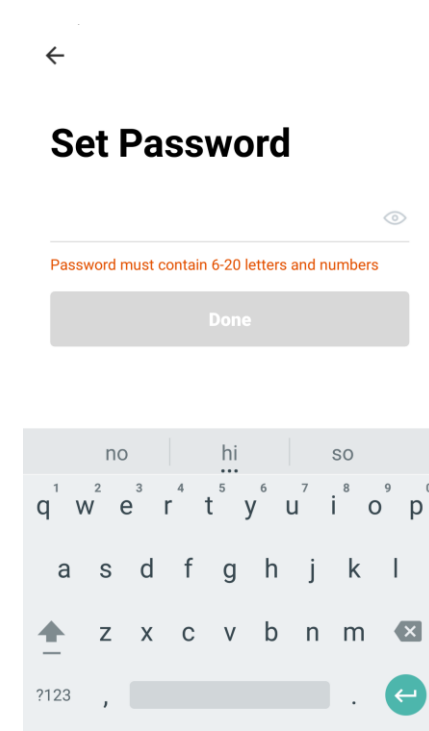

6. The app is now registered. It will automatically log you in following registration.

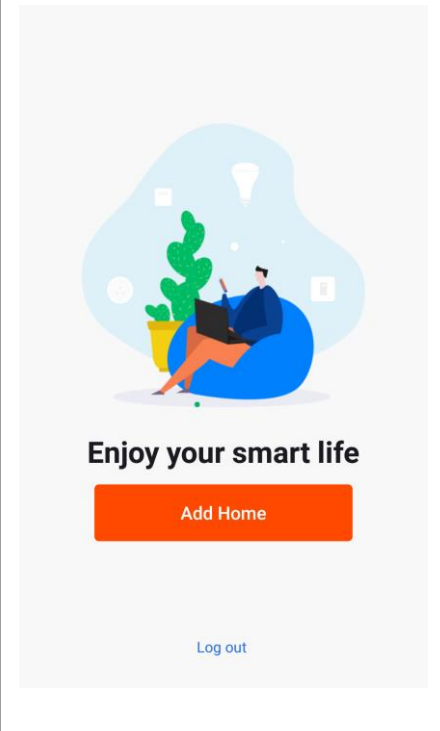

## SETTING UP YOUR HOME WITHIN THE APP

TUYA is designed so it can work with a large number of compatible smart devices within your home. It can also be set up to work with multiple devices within different houses. As such, during the setup process the app requires that different areas are created and named to allow easy management of all your devices. When devices are then added, they are assigned to one of the rooms you have created.

### CREATING ROOMS

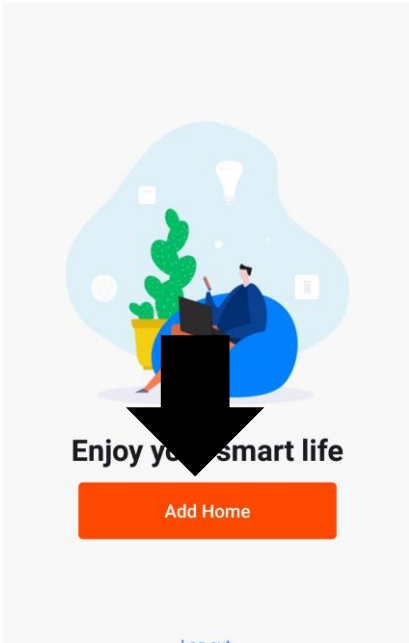
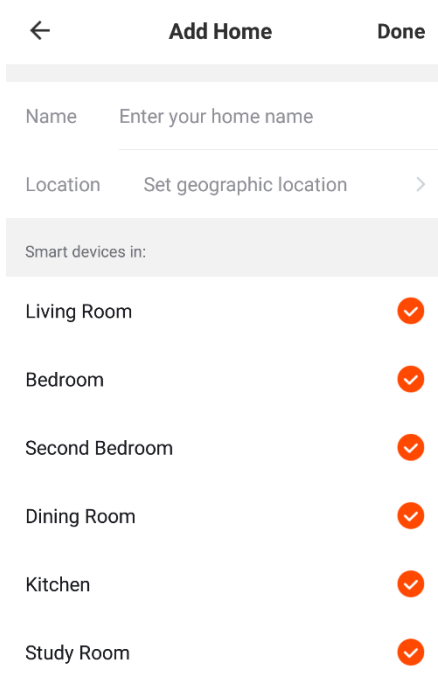
<p>1. Press on the ADD HOME button.</p> 	<p>2. Type in a name for your home</p> <p>3. Press on the location button to select the location of your home. (See <b>SETTING YOUR LOCATION</b> below)</p> <p>4. New rooms can be added by pressing the <b>ADD ANOTHER ROOM</b> option at the bottom. (See <b>ADD ANOTHER ROOM</b> below)</p> <p>5. Untick any rooms that are not required on the app.</p> <p>6. Press <b>DONE</b> in the top right corner.</p> 
--	---

### SETTING YOUR LOCATION

Use your finger to move the orange HOME symbol.

When the symbol is in the approximate location of your home, press the confirm button in the top right corner.

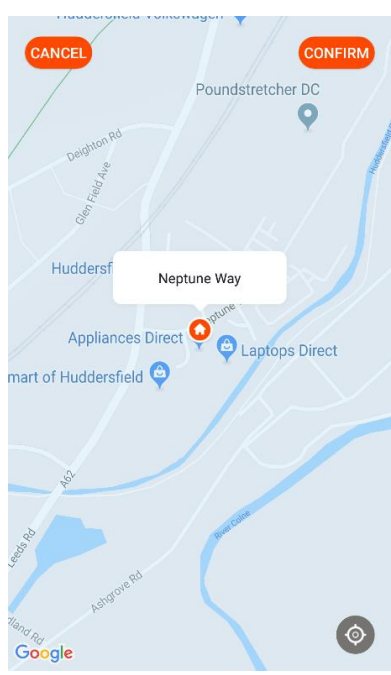

### ADD ANOTHER ROOM

Type in the name of the room, and press Done in the top right corner

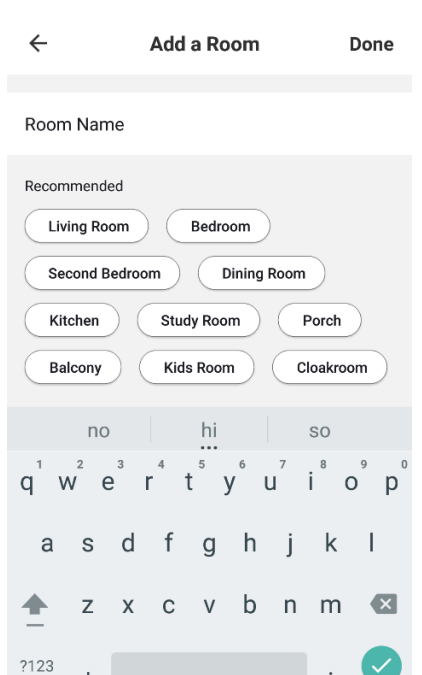

## CONNECTING USING QUICK CONNECTION

Before initiating the connection, make sure the unit is in standby mode, with the WiFi light flashing twice per second. If not, follow the instructions for changing the connection mode. Ensure your phone is connected to the WiFi network. (We advise turning mobile data off during setup)

1. Open app and press “+” to add device, or use the add device button

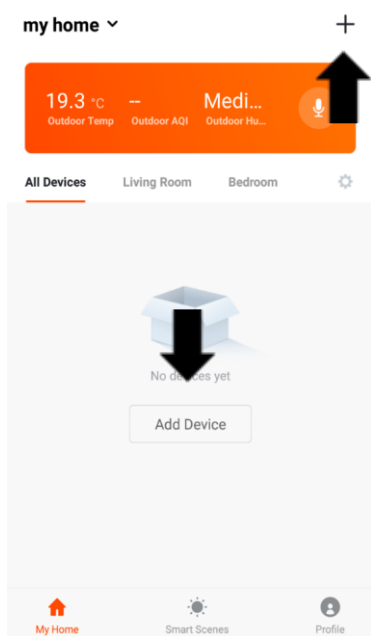

2. Select the type of device as “Dehumidifier” in the Small Home Appliance tab.

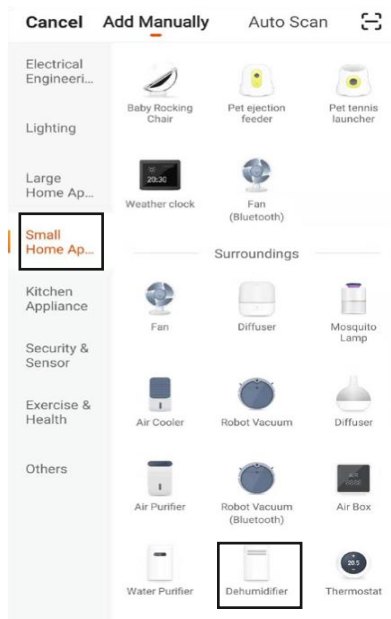

3. Ensure the WiFi light on the dehumidifier is flashing twice per second, then press on the orange button at the bottom of the screen to confirm.

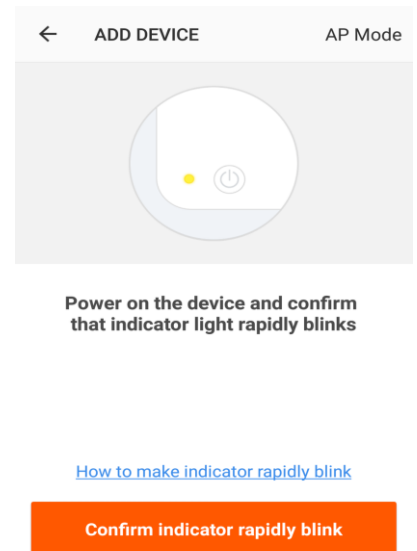

4. Enter your WiFi password and press confirm.

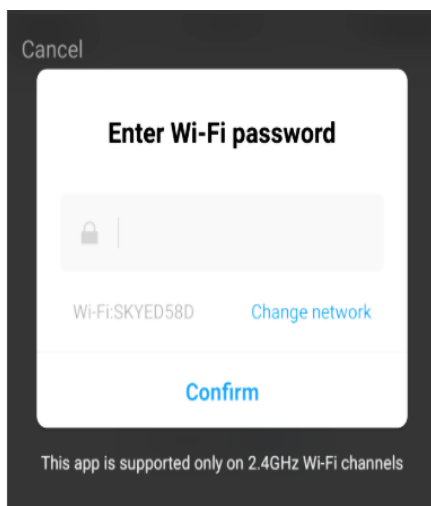

5. This will then transfer the settings to the dehumidifier. Wait for this to complete. If this fails, retry. If still unsuccessful please review the troubleshooting section for further help.

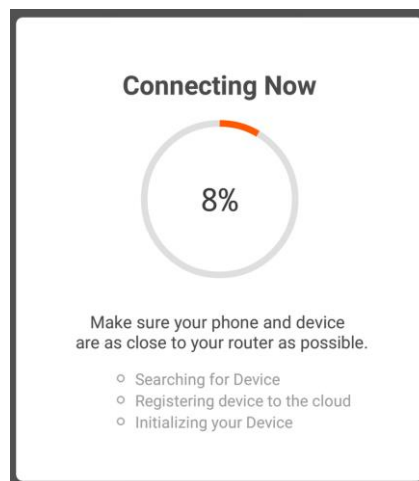

## CONNECTING USING AP MODE (ALTERNATIVE METHOD)

Before initiating the connection, make sure the unit is in standby mode, with the WiFi light flashing once per second. If not, follow the instructions for changing the connection type. Ensure your phone is connected to the WiFi network. (We advise turning mobile data off during setup)

1. Open app and press “+” to add device, or use the add device button

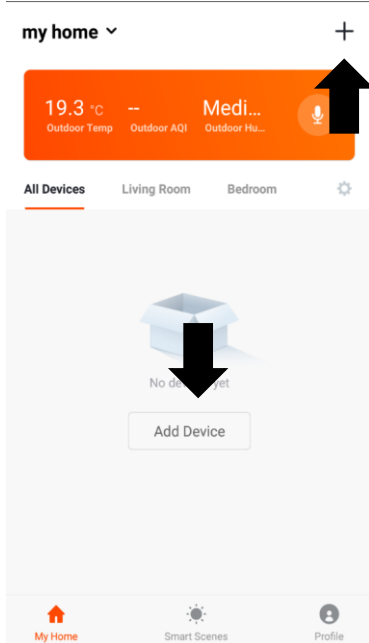

2. Select the type of device as “Dehumidifier”

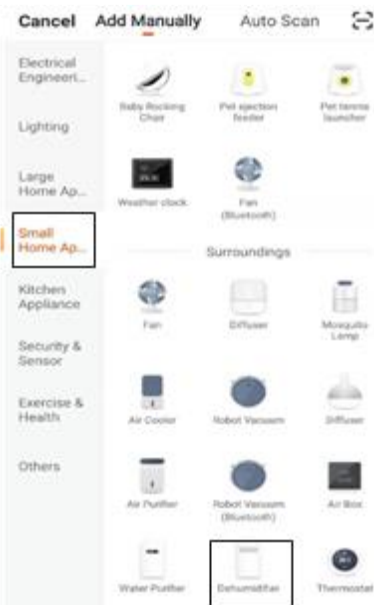

3. Press on the AP mode button in the top right of the screen.

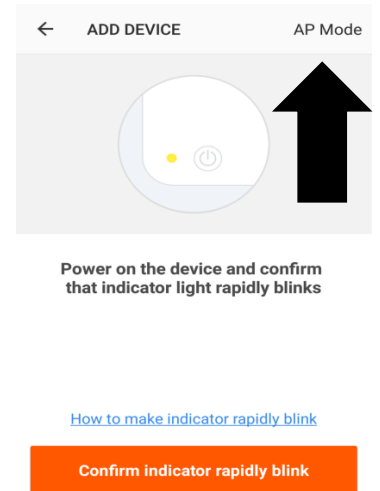

4. Ensure the WiFi light on the dehumidifier is slowly flashing (once per second), then press on the orange button at the bottom of the screen to confirm

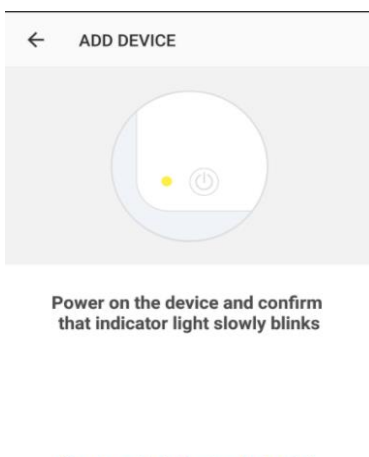

5. Enter your WiFi password and press confirm.

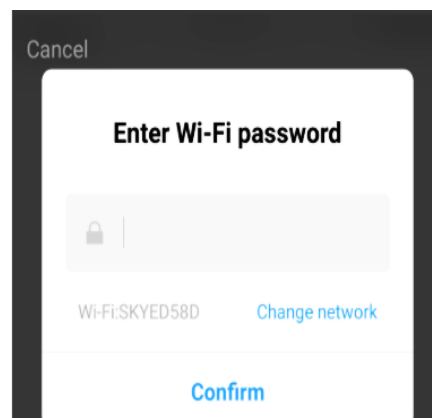

6. Go to network settings in your phone and connect to the “SmartLife xxx” connection. There is no password to enter. Then return back to the app to complete setup.

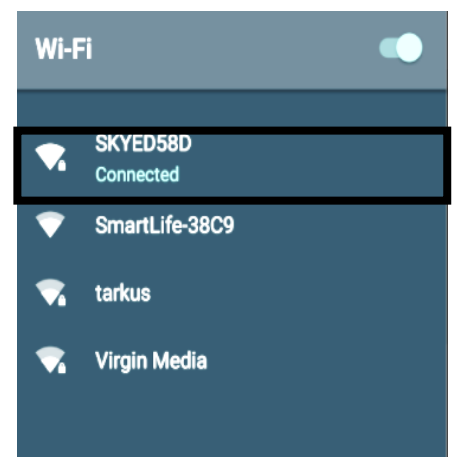

This will then transfer the settings to the dehumidifier. Once the connection process has completed, go back to the network settings on your phone to ensure your phone has reconnected to your WiFi router.

# CONTROLLING YOUR DEVICE THROUGH THE APP

## THE HOME SCREEN

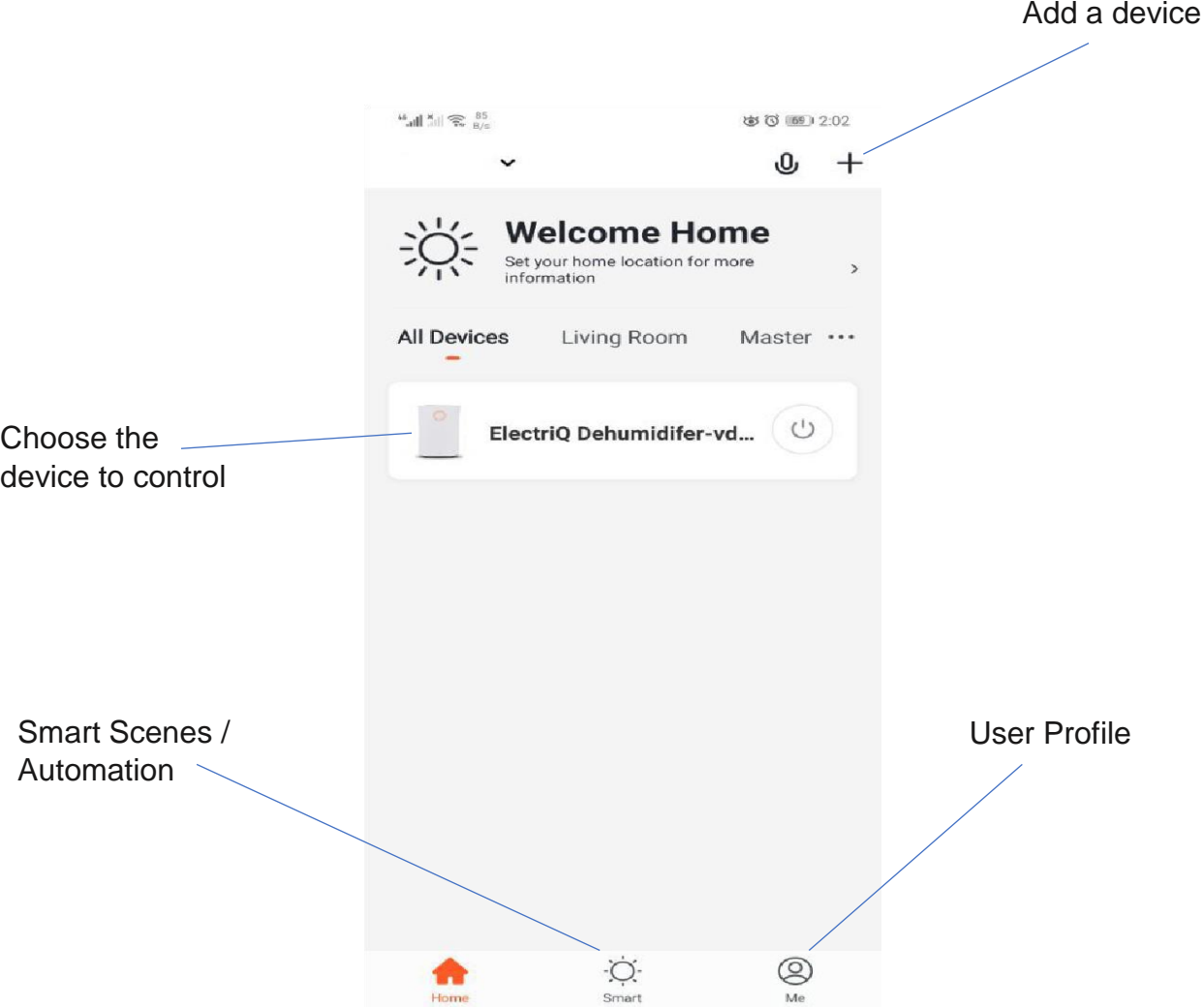

## DEVICE SCREEN

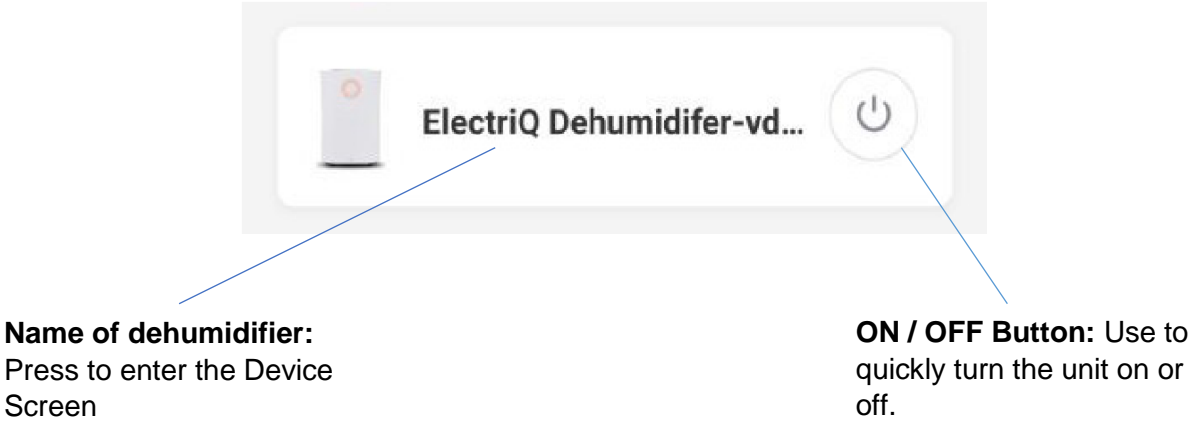

## DEVICE SCREEN

The device screen is the main control screen for the dehumidifier, providing access to the controls to amend the functions of the dehumidifier

**Back:** Return to the Home Screen

**Profile:** Use to change the name of the dehumidifier and amend user settings.

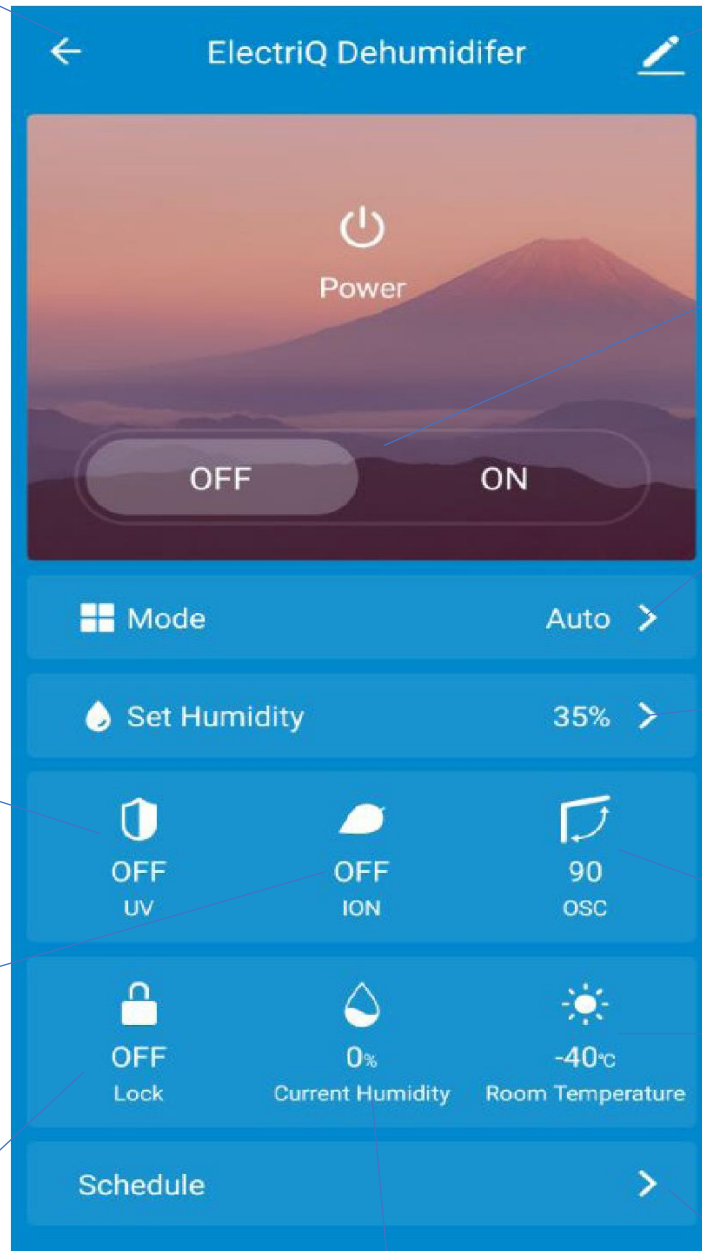

**On / Off Slider:** Use to turn the dehumidifier On and Off

**Mode:** Change the operating mode between Auto, Fan, High and Low

**UV Light:** Allows the UV Light to be turned on and off

**Desired Humidity:** Change the desired humidity between 35°C and 80°C

**Ioniser:** Allows the Ioniser to be turned on and off

**Oscillation:** Set the position of the louvres

**Room Temperature:** Shows the current room temperature

**Child Lock:** Allows the control panel on the dehumidifier to be disabled / enabled

**Room Humidity:** Shows the current room humidity

**Schedule:** Allows an On of Off time to be set. A number of scheduled operations can be input to create automatic operation

## SMART SCENES

Smart Scenes is a powerful tool providing the option to customise the operation of the dehumidifier based both on conditions within the room and outside influences. This gives the user the option of specifying much more intelligent actions. These are split into two categories Scene and Automation.

### SCENE

Scene allows for a one-touch button to be added to the Home screen. The button can be used to change a number of settings in one go and can change all the settings within the unit. A number of scenes can easily be set up, allowing the user to easily change between a number of preset configurations.

Below is an example of how to set up a scene:

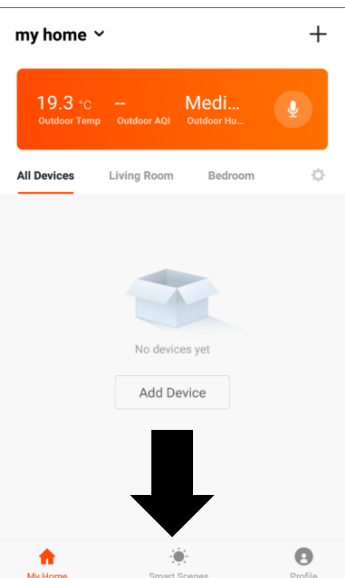
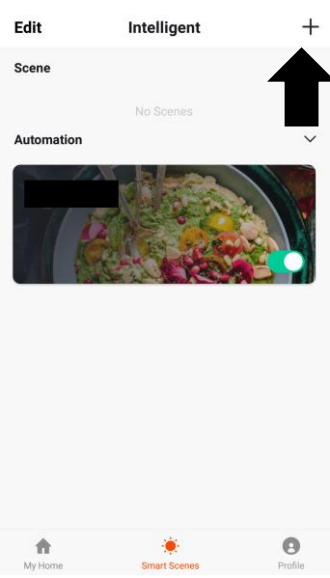
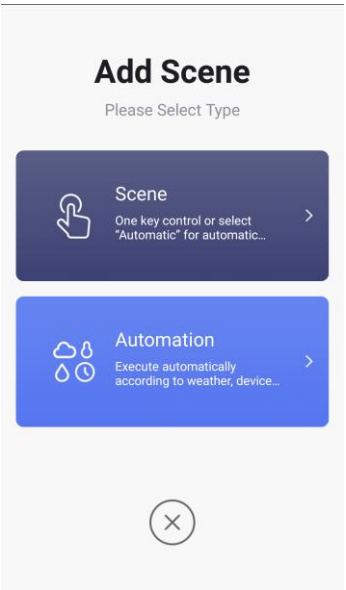
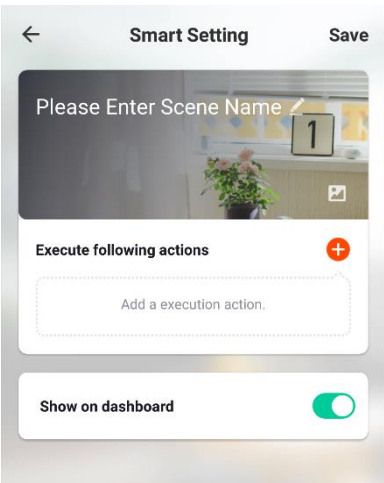
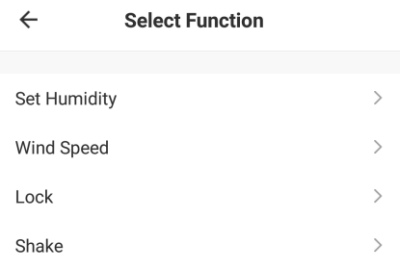
<p>1. Press on the Smart Scene tab at the bottom of the Home screen</p> 	<p>2. Press on the Plus in the top right corner to add a smart scene.</p> 	<p>3. Select Scene to create a new Scene</p> 
	<p>4. Press the Pen next to "Please Enter Scene Name" to input the name for your Scene</p> <p>Show on Dashboard: Leave this on if you require the scene to be displayed as a button on the Home Screen</p> <p>Press the Red Plus to add the action required. Then select the dehumidifier from the list of devices.</p>	<p>5. Chose the function, set the value for the function, and then press the back button in the top right corner, to return to the previous screen.</p> 
<p>6. Once all the functions required have been added, press the Save button in the top right corner to finalise and save your new Scene</p>		

## AUTOMATION

Automation allows an automatic action to be set up for the device. This can be triggered by the Time, indoor temperature, humidity of the room, weather conditions, and a range of other influences.

1. Press on the Smart Scene tab at the bottom of the Home screen

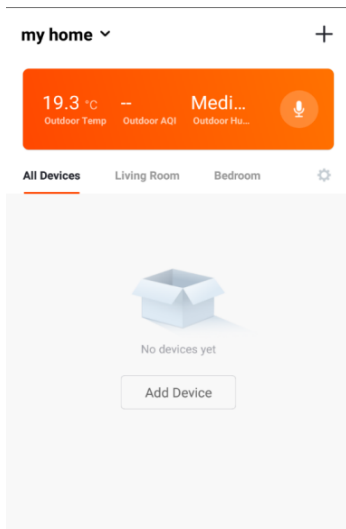

2. Press on the Plus in the top right corner to add a smart scene.

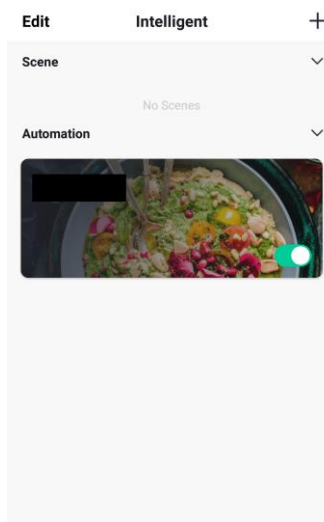

3. Select Automation to create a new Automation Scene

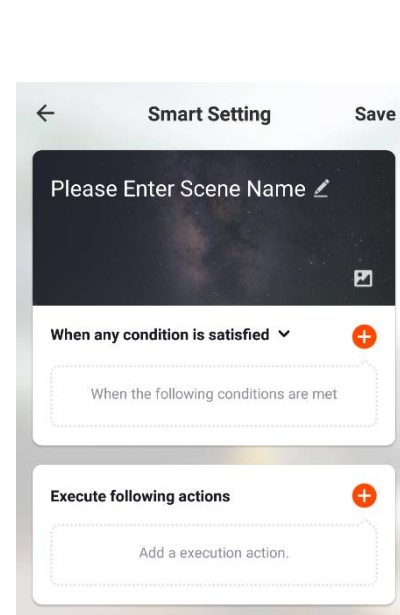
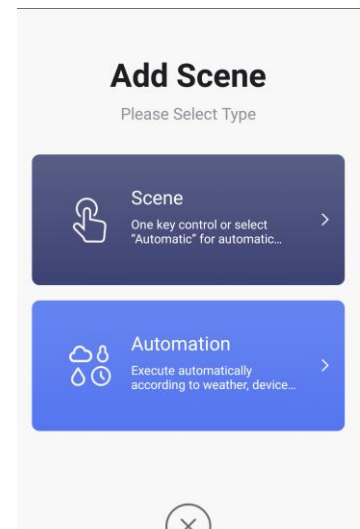

4. Setup is very similar to the scene setup on the previous page, and includes an extra section for specifying a trigger for the scene to start.

Press the Pen next to "Please Enter Scene Name" to input the name for your Scene

Press the Red Plus next to "When any condition is satisfied" to add the trigger

Press the Red Plus next to "Execute following actions" to add the action required. Then select the dehumidifier from the list of devices.

5. Select the condition when the automation should start. A number of triggers can be combined.

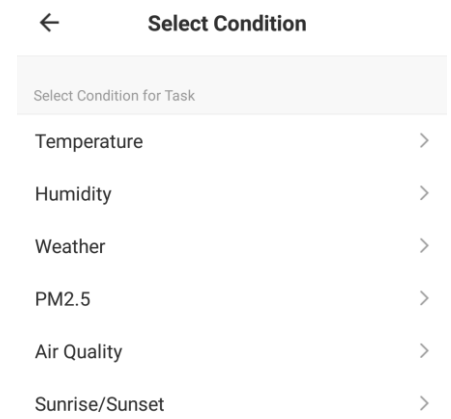

6. Chose the function, set the value for the function, and then press the back button in the top right corner, to return to the previous screen.

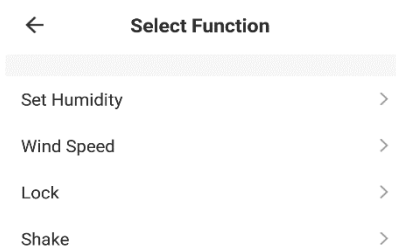

7. Once all the functions required have been added, press the Save button in the top right corner to finalise and save your new scene.

The automation is now set up, it can be turned on and off using the toggle on the image shown on step 2.



## DEVICE DETAILS SCREEN

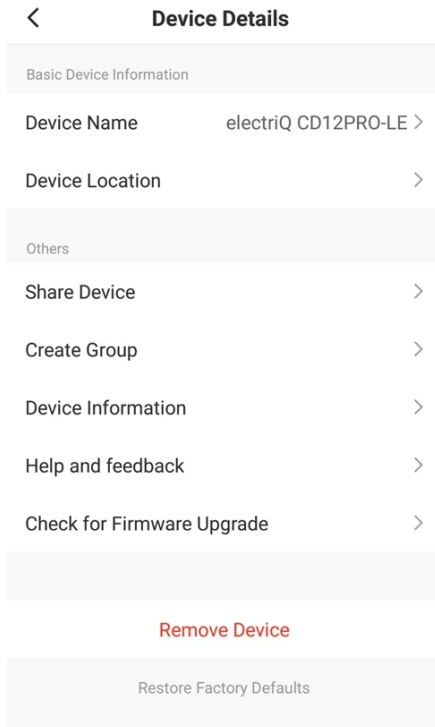

The device details screen gives you the option to edit the details for the device, and use some of its additional features. The device details screen can be accessed from the device screen by pressing on the symbol in the top right hand corner.

### CHANGING THE NAME OF YOUR DEVICE

The top option within this allows you to change the name of the device to something relevant to the use of the product, such as “Living Room Dehumidifier”. Within the menu, you also have the option of setting up a pattern lock or change your password.

### DEVICE SHARING

This allows you to share access to the controls of your dehumidifier with friends and family.



## PROFILE TAB

The Profile tab allows you to make changes to the app, such as setting up a username and editing or adding rooms.

Within the Profile tab, you are also able to change settings related to the app itself.

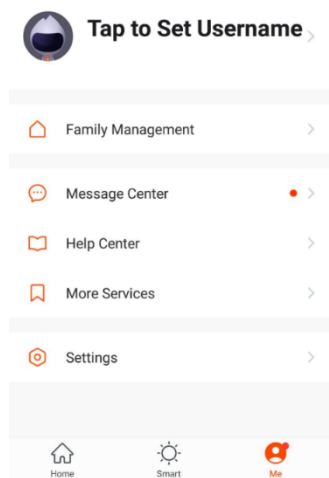

## CONNECTION TROUBLESHOOTING

1. Check whether the device is powered on and is in the correct standby mode, if not please refer to the CHANGING BETWEEN CONNECTION MODES section on page 12.
2. Ensure the wifi password has been entered into the app correctly (Case sensitive)
3. Check that the phone is connected to the wifi you are connecting the device to.
4. Ensure the network you are connecting it to is 2.4Ghz (5Ghz wifi networks are not supported), and that there is a strong wifi signal to the item.
5. If your router is dual band, ensure that the 2.4ghz network has a different network name (SSID). Further advice on changing router settings will be available from your Internet service provider / Router manufacturer.
6. Check the settings on the router. Encryption should be WPA2-PSK and authorisation type should be set to AES
7. Try using the alternative connection method. i.e. If connection is failing when attempting to connect through CF mode, try AP mode.

## CARE AND MAINTENANCE

Always shut off the unit and unplug it from the mains before cleaning or performing any maintenance. When it is not in use for long periods, it is advisable to remove the plug from the power socket. Do not use chemical solvents (such as benzene, alcohol or gasoline) as they may cause irreversible damage to the unit.

### FILTER CLEANING

The Air-inlet may gather dust easily, please clean it often with a soft, damp cloth. If the filter is covered by dust, the airflow and the performance of the unit will be affected, it may even cause damage to the unit. We recommend that you regularly clean the filters. The dehumidifier must be disconnected from the socket before maintenance and the filters must be allowed to fully dry before re use.

1. Remove the filters from the unit, and tap the dust away.
2. Clean the carbon (Optional) and the mesh filter with a vacuum cleaner or soft-brush.
3. If dirt and grease is accumulated wash the mesh filter in hot soapy water.
4. Replace the filters in position as shown in the diagram.

Note: Never use the unit without the antibacterial mesh dust filter. The active carbon filter is optional and should be replaced if necessary after 1-1 ½ years of usage.

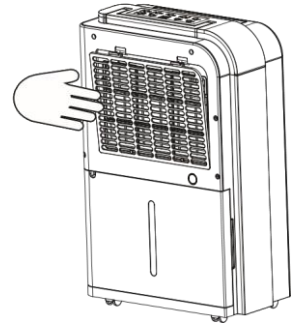

### CLEAN THE GRILLE AND CASE

Use water and a mild detergent to clean the washable mesh filters. Do not use bleach or abrasives. Do not splash water directly onto the main unit. Doing so may cause an electrical shock and can lead to the insulation to deteriorate, or cause the unit to rust. The air intake and outlet grilles get soiled easily, so use a vacuum attachment or soft brush to clean. Wipe the dehumidifier body with a soft damp cloth or kitchen towel.

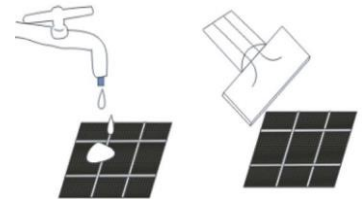

### CLEAN THE WATER TANK

Every few weeks, clean the tank to prevent growth of mould, mildew and bacteria. Partially fill the tank with clean water and add a little mild detergent. Swish it around and then empty the tank and rinse. NOTE: Do not use a dishwasher to clean the tank. After cleaning and drying the tank must be reinserted securely into dehumidifier in order to restart operation.

### END OF SEASON MAINTENANCE :

Empty and clean the water tank.

Clean the unit and the filters as per cleaning procedure above.

Coil the power cord on the special cord storage rest at the back of the unit.

Cover the unit and keep it in a dry place.

### POWER CORD MAINTENANCE AND REPLACEMENT

If the power cord is damaged, it could cause a short circuit or become a fire risk. Please avoid pulling the cord, twisting or pressing it and keep it away from pets. If the power cord is damaged, power the unit off and unplug it immediately. Contact an electrician or service centre for repairs; do not attempt to repair the unit yourself.

## FREQUENTLY ASKED QUESTIONS

### **Why doesn't the dehumidifier seem to extract much water if the temperature is low?**

This is a compressor dehumidifier which works best in temperatures above 15°C. If the temperature is low and the air is dryer than the setting on the humidistat the unit will not extract water. If you want to use a dehumidifier for outside buildings, unheated properties, boats or garages please check our desiccant range.

### **Why doesn't the unit work /or stops suddenly?**

The water tank may be full or displaced. To rectify: empty the tank and carefully place the tank back in the unit. Also, the unit may be running in dehumidifying mode with a low room temperature. Please check if the room temperature is lower than 5°C. If so, the unit will stop working while in dehumidifying mode. (unit may be defrosting). The ambient operating range is between 5°C and 35°C with a relative humidity ranging from 30% to 80%. For maximum efficiency use the unit between 15°C and 32°C.

**Sometimes cold and/or hot air comes out from the air outlet grill, why?** When the unit is in dehumidifying mode it absorbs humid air from room and freezes it to reduce the humidity.

During the cold cycle there should be cold air coming out of the unit During the hot cycle hot dry air should be coming out of the outlet grill.

## APPENDIX

Disposal: Do not dispose this product as unsorted municipal waste. Collection of such waste must be handled separately as special treatment is necessary.



Recycling facilities are now available for all customers at which you can deposit your old electrical products. Customers will be able to take any old electrical equipment to participating civic amenity sites run by their local councils. Please remember that this equipment will be further handled during the recycling process, so please be considerate when depositing your equipment. Please contact the local council for details of your local household waste recycling centres.

## TROUBLESHOOTING

ISSUE	CAUSE	SOLUTION
Hot or cold air being produced	Normal Operation	When the unit is in dehumidifying mode it absorbs humid air from room and freezes it to reduce the humidity. During the cold cycle there should be cold air coming out of the unit During the defrost cycle hot dry air should be coming out of the outlet grill.
Unit does not operate	Is the plug properly inserted in the socket?	Insert the plug into the socket and turn the switch on.
	Does the tank full indicator is red?	Tank full, float displaced or tank not properly inserted. Empty tank, check float and make sure tank is properly inserted in unit.
Front louvres do not open	Louvre motor is blocked	Check if anything is blocking the louvre Try to move gently the louvres up and down while the unit is off If the above fails return the unit to service centre
Dehumidifier does not extract water	Is the unit set to a humidity level lower than the one in the room?	Set the humidity level on the humidistat below current humidity reading.
	Is the temperature too low for water extraction to be efficient?	Increase temperature in the room or reposition the unit.
	Is any intake grill or discharge blocked? Is the unit too close to walls?	Remove obstructions and restart the unit. Ensure a distance of at least 20 [cm between the unit & walls
Airflow seems weak	Is filter dirty or clogged?	Please service the filters regularly as per user manual.
Unit is noisy during operation	Is the unit on an uneven surface?	Please place on flat horizontal surface.
	Is filter clogged?	Please service the filters regularly as per user manual.
E3 or E4	Humidity sensor error	Use the unit within the prescribed humidity range. Unplug the unit, rest and plug it back in. If error repeats, call for service centre.
E1 or E2	Temperature sensor error	Use the unit within the prescribed temperature range. Unplug the unit, rest and plug it back in. If error repeats, call for service centre.
E5 or E6	Abnormal Coil sensor temperature or current	Use the unit within the prescribed humidity and temperature range. Unplug the unit, rest and plug it back in. If error repeats, call for service centre.
Defrost light on and unit stops regularly	Unit is defrosting	Allow the unit to automatically defrost. The protection will clear after the unit self-defrosts. Increase temperature in the room if this repeats too often
Tank full red light	Water tank full notification	Tank is full or is not in the right position-- Empty the tank and replace in the right position.
Any other malfunctions will need to be reported to electriQ service centre. Do not attempt unauthorised repairs as these may invalidate the warranty.		

## TECHNICAL SPECIFICATIONS

Model	<b>CD25PRO-LE-V2</b>
Voltage	1Ph, 220-240V~ 50Hz
Dehumidifying capacity	25 L / day (at 30°C / 80%RH)
Fan Speeds	2
Power Consumption	320W
Running Amps	1.72 Amps
Tank Capacity	5 litres
Humidity settings range	35%~80%
IP RATING	IPX1
Refrigerant	R290, 95 grams
Airflow	210 m <sup>3</sup> /h
High / Low Pressure	3.2/0.7MPa
Max noise level	48 dB(A)
Filters	carbon (optional)
Dimensions mm (WxHxD)	400 x 625 x 220 mm
Weight	17.5 kgs
GWP	3.3

## electriQ UK SUPPORT

[www.electriQ.co.uk/support](http://www.electriQ.co.uk/support)

Please, for your own convenience, make these simple checks before calling the service line.

If the unit still fails to operate call: 0871 620 1057 or complete the online form

1. Is the unit plugged into the mains?
2. Is the fuse OK?
3. Switch the unit off and wait three minutes to see if the issue is resolved. Restart the unit.

Office hours: 9AM - 5PM Monday to Friday

[www.electriQ.co.uk](http://www.electriQ.co.uk)  
**Unit J6, Lowfields Business Park**  
Lowfields Way, Elland  
West Yorkshire, HX5 9DA

## DECLARATION OF CONFORMITY

Hereby, electriQ declares that this Portable air conditioner is in compliance with Directive 2014/53/ EU. The full text of the EU declaration of conformity is available at the following internet address:

<https://www.electriQ.co.uk/content/declaration-of-conformity>